



US009746010B2

(12) **United States Patent**
Roy et al.

(10) **Patent No.:** **US 9,746,010 B2**
(45) **Date of Patent:** **Aug. 29, 2017**

(54) **NOISE CONTROL OF CAVITY FLOWS USING ACTIVE AND/OR PASSIVE RECEPTIVE CHANNELS**

USPC 137/825, 827; 315/111.21, 111.41, 315/111.61; 313/231.31
See application file for complete search history.

(71) Applicant: **University of Florida Research Foundation**, Gainesville, FL (US)

(56) **References Cited**

(72) Inventors: **Subrata Roy**, Gainesville, FL (US); **Arnob Das Gupta**, Gainesville, FL (US)

U.S. PATENT DOCUMENTS

(73) Assignee: **UNIVERSITY OF FLORIDA RESEARCH FOUNDATION, INCORPORATED**, Gainesville, FL (US)

- 3,371,491 A * 3/1968 Pinter F02K 9/82 239/265.19
- 3,521,837 A * 7/1970 Papst B64C 21/06 244/130
- 4,664,345 A * 5/1987 Lurz B64C 21/025 244/130
- 6,615,857 B1 * 9/2003 Sinha G05D 7/0629 137/14
- 6,752,358 B1 * 6/2004 Williams B64C 1/12 244/208
- 7,183,515 B2 * 2/2007 Miller B64C 23/005 219/121.5
- 7,334,394 B2 * 2/2008 Samimy F01D 25/30 239/265.19
- 7,686,256 B2 * 3/2010 Miller B64C 21/04 244/198

(*) Notice: Subject to any disclaimer, the term of this patent is extended or adjusted under 35 U.S.C. 154(b) by 233 days.

(21) Appl. No.: **14/680,887**

(22) Filed: **Apr. 7, 2015**

(Continued)

(65) **Prior Publication Data**

FOREIGN PATENT DOCUMENTS

US 2015/0292533 A1 Oct. 15, 2015

WO 2011/156408 12/2011

Related U.S. Application Data

Primary Examiner — Jessica Cahill

(60) Provisional application No. 61/977,288, filed on Apr. 9, 2014.

Assistant Examiner — Minh Le

(74) *Attorney, Agent, or Firm* — Thomas | Horstemeyer, LLP

(51) **Int. Cl.**
F15C 1/04 (2006.01)
F15D 1/12 (2006.01)
F15D 1/00 (2006.01)

(57) **ABSTRACT**

(52) **U.S. Cl.**
CPC **F15D 1/12** (2013.01); **F15D 1/0025** (2013.01); **F15D 1/0075** (2013.01)

An apparatus comprises a surface that is configured to be exposed to a fluid stream and a cavity wall that forms at least a portion of a cavity. A first channel opening is formed in the surface, and a second channel opening is formed in the cavity wall. A channel extends from the first channel opening in the cavity wall to the second channel opening in the surface.

(58) **Field of Classification Search**
CPC F15D 1/12; F15D 1/0025; F15D 1/0075; Y10T 137/218; Y10T 137/2191

19 Claims, 7 Drawing Sheets

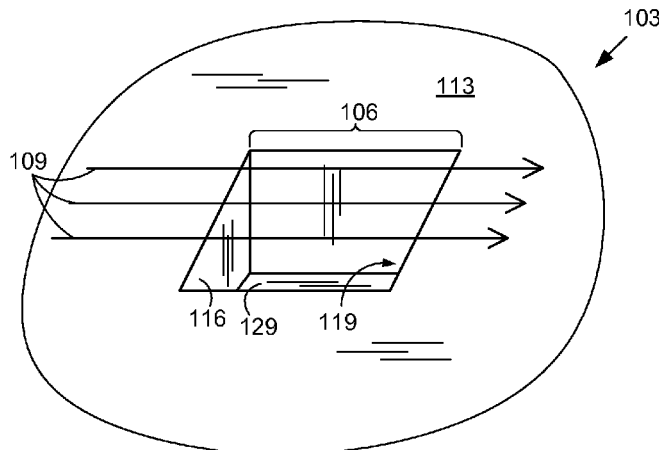

(56)

References Cited

U.S. PATENT DOCUMENTS

7,748,664 B2 *	7/2010	Boespflug	B64C 23/005 239/265.19	9,067,674 B2 *	6/2015	Nordin	B64C 23/005
7,802,760 B2 *	9/2010	Webster	F01D 5/145 244/207	9,074,613 B2 *	7/2015	Bonnet	B64C 23/005
7,967,258 B2 *	6/2011	Smith	B64C 21/08 239/102.2	2002/0134891 A1 *	9/2002	Guillot	B64C 3/00 244/204.1
7,984,614 B2 *	7/2011	Nolcheff	F23C 99/001 60/726	2004/0118973 A1 *	6/2004	Malmuth	B64C 5/12 244/75.1
8,016,247 B2 *	9/2011	Schwimley	B64C 23/005 244/200	2006/0273197 A1 *	12/2006	Saddoughi	B05B 1/08 239/265.17
8,091,837 B2 *	1/2012	Frankenberger	B64C 21/06 244/209	2007/0089795 A1 *	4/2007	Jacob	B64C 23/005 137/827
8,235,072 B2	8/2012	Roy		2010/0258046 A1 *	10/2010	Berger	B63B 1/38 114/274
8,235,309 B2 *	8/2012	Xu	B64C 21/04 239/102.1	2011/0253842 A1 *	10/2011	Silkey	B64C 23/005 244/205
8,490,926 B2 *	7/2013	Clingman	B64C 21/04 244/207	2012/0291874 A1 *	11/2012	Tanaka	F01D 5/145 137/13
9,003,990 B2 *	4/2015	Jones	B63B 1/38 114/67 A	2013/0038199 A1 *	2/2013	Roy	H05H 1/24 313/231.31
				2013/0277502 A1 *	10/2013	Bauer	B64C 21/08 244/208

* cited by examiner

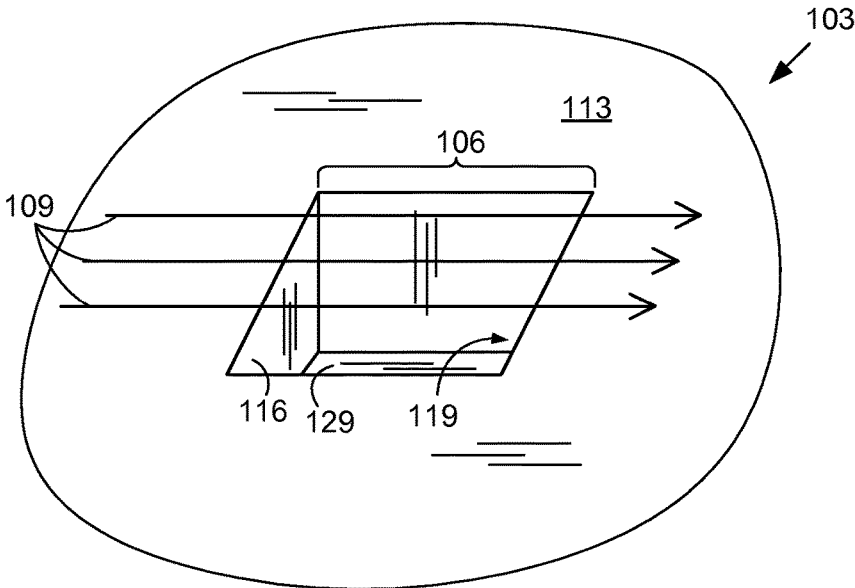

FIG. 1A

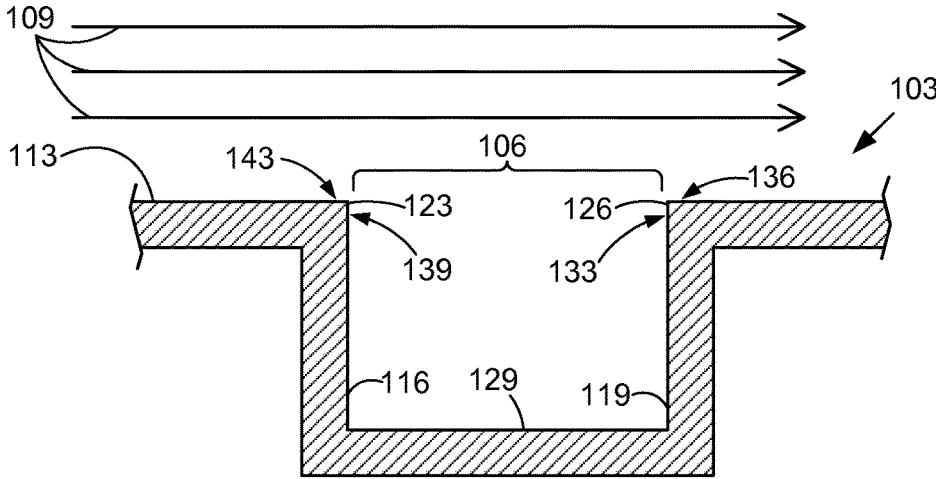

FIG. 1B

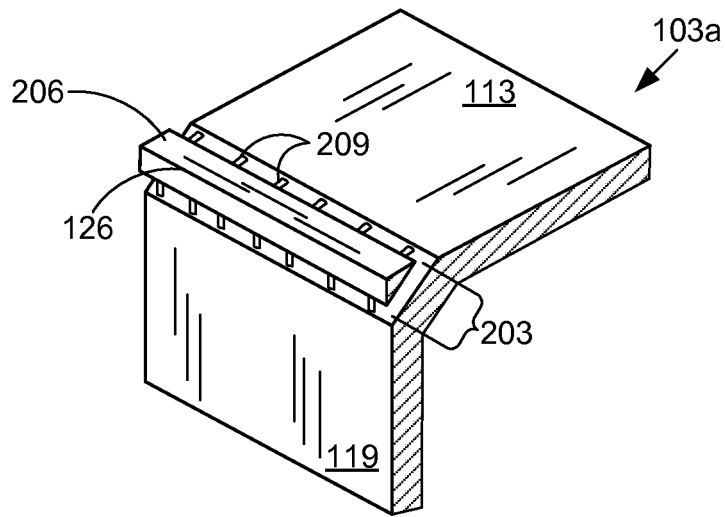

FIG. 2A

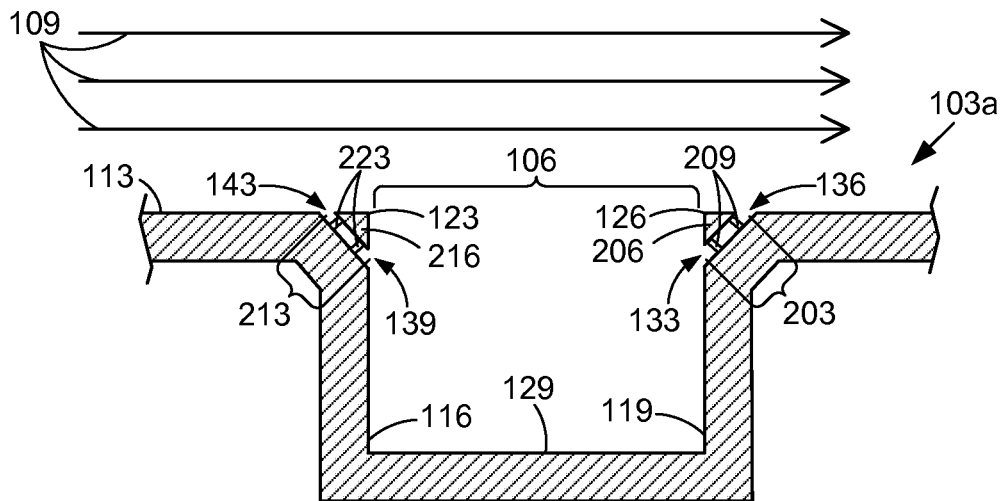

FIG. 2B

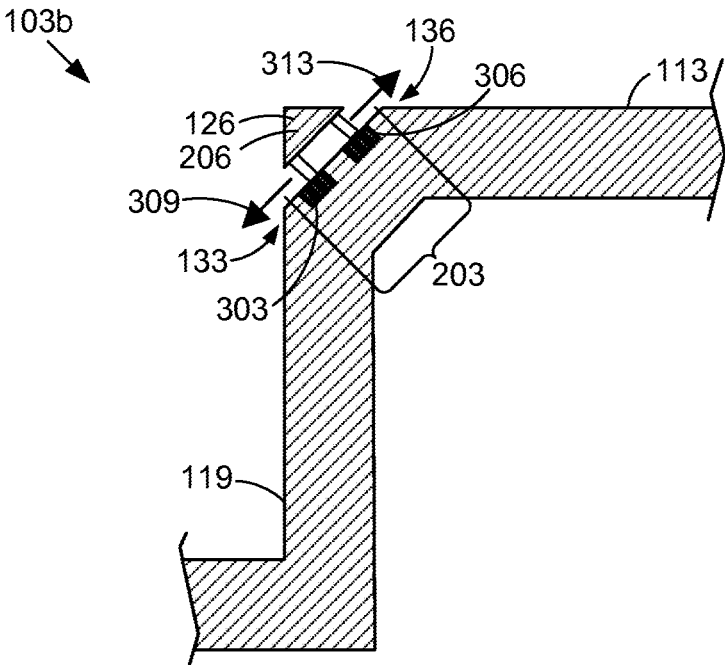

FIG. 3

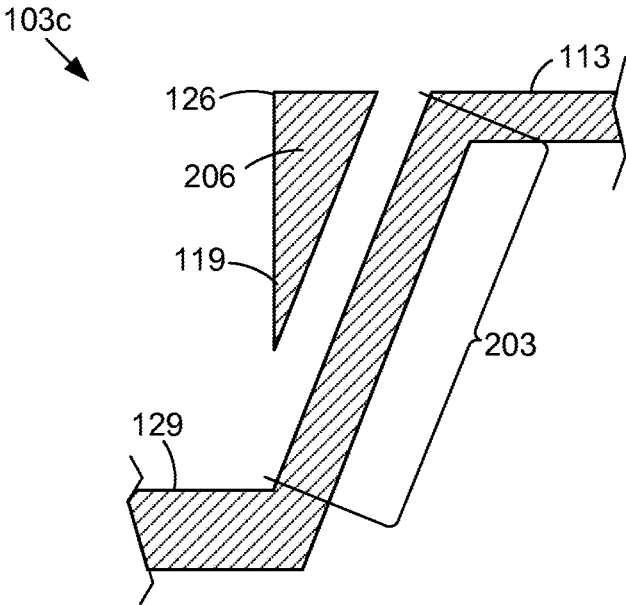

FIG. 4

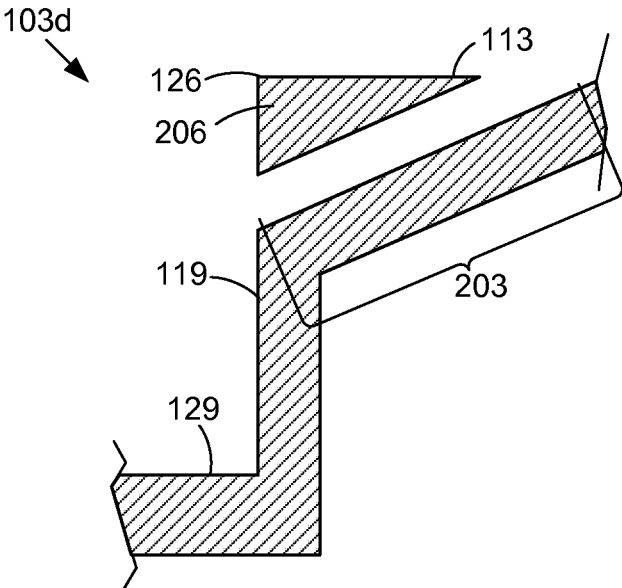

FIG. 5

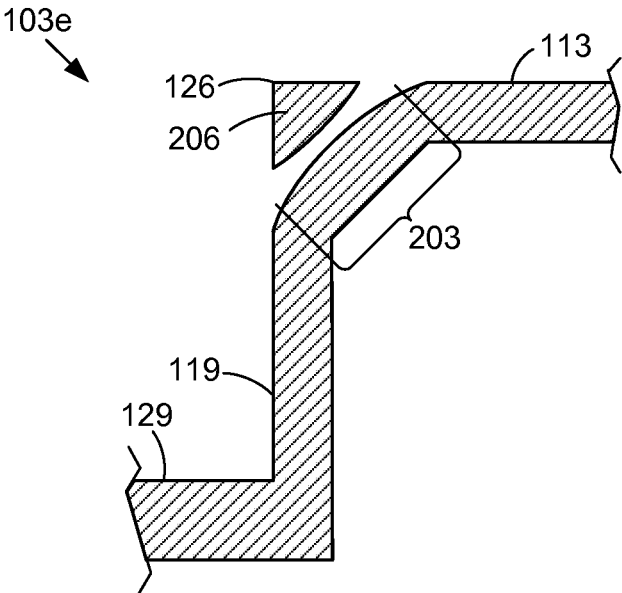

FIG. 6

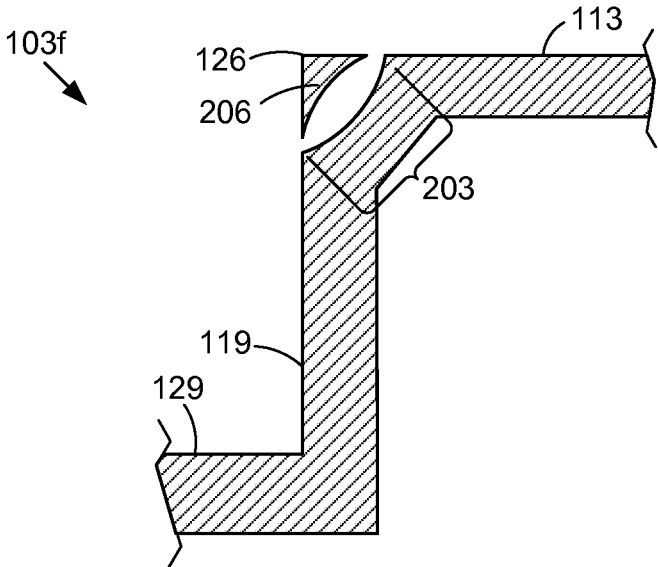

FIG. 7

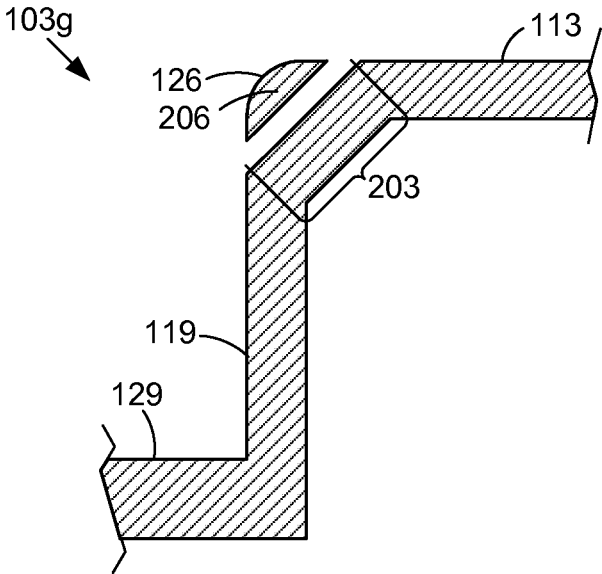

FIG. 8

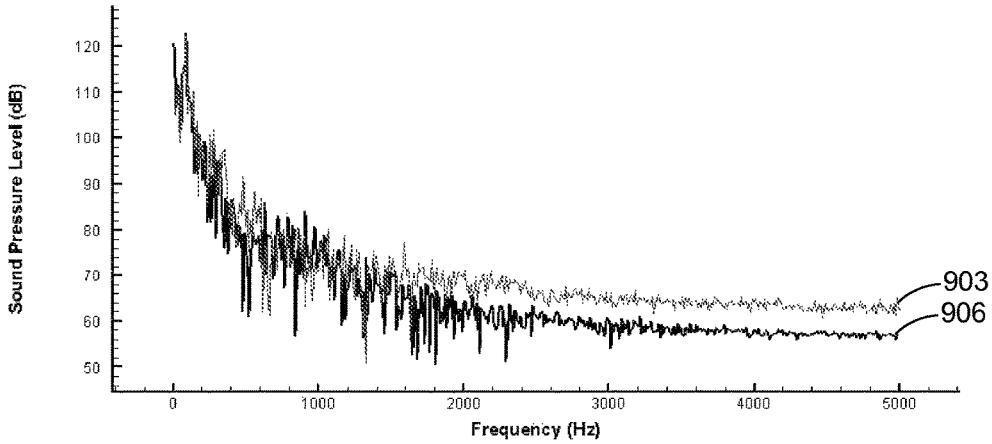

FIG. 9

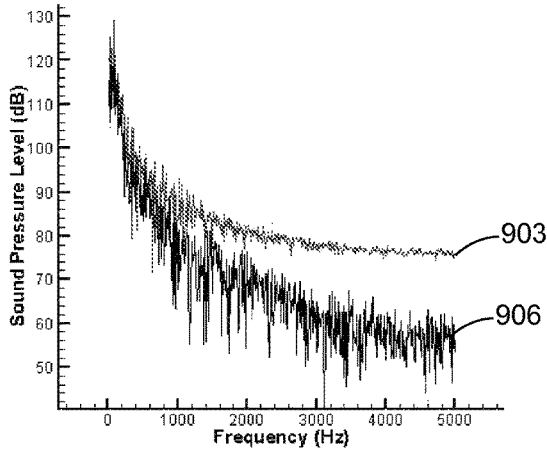

FIG. 10

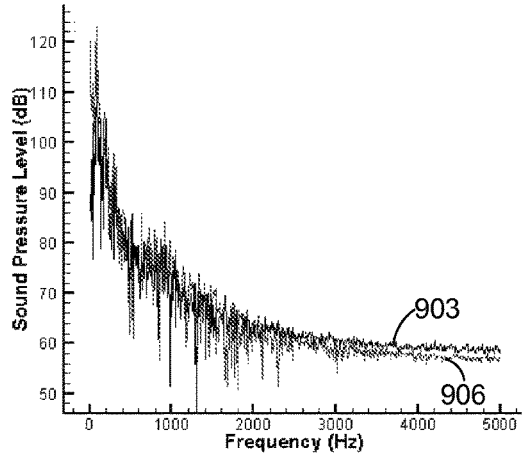

FIG. 11

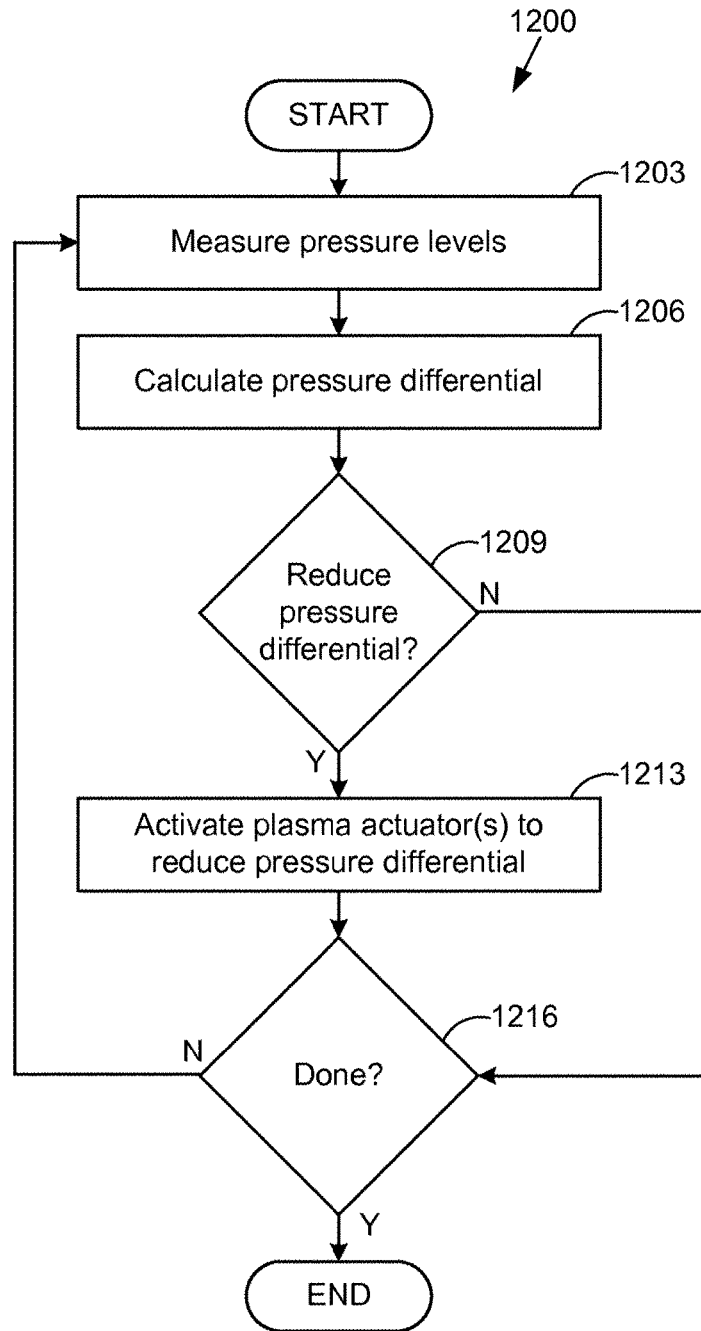

FIG. 12

1

NOISE CONTROL OF CAVITY FLOWS USING ACTIVE AND/OR PASSIVE RECEPTIVE CHANNELS

CROSS-REFERENCE TO RELATED APPLICATIONS

The present application is a non-provisional application of, and claims priority to, U.S. Provisional Application No. 61/977,288, filed on Apr. 9, 2014 and titled "NOISE CONTROL OF CAVITY FLOWS USING ACTIVE AND/OR PASSIVE RECEPTIVE CHANNELS," which is incorporated by reference herein in its entirety.

BACKGROUND

Fluidic flow over an open cavity may generate impinging shear layers in the fluid. These impinging shear layers may result in pressure oscillations. Free shear layers in an open cavity become unstable and create relatively large vortical structures which may impinge on the trailing edge of the cavity and produce periodic acoustic waves. These waves may propagate upstream in the fluid and impact the shear layer at the layer separation point, thereby causing instability in the fluid.

BRIEF DESCRIPTION OF THE DRAWINGS

Many aspects of the present disclosure can be better understood with reference to the following drawings. The components in the drawings are not necessarily to scale, with emphasis instead being placed upon clearly illustrating the principles of the disclosure. Moreover, in the drawings, like reference numerals designate corresponding parts throughout the several views.

FIG. 1A is a drawing of a first example of a body with a cavity being exposed to a fluid stream according to various embodiments of the present disclosure.

FIG. 1B is a cross-sectional view of the body of FIG. 1A with the cavity being exposed to a fluid stream according to various embodiments of the present disclosure.

FIG. 2A is a drawing of a second example of a body with a cavity that may be exposed to a fluid stream according to various embodiments of the present disclosure.

FIG. 2B is a cross-sectional view of the body of FIG. 2A with the cavity being exposed to a fluid stream according to various embodiments of the present disclosure.

FIG. 3 is a cross-sectional view of an example of plasma actuators disposed in a channel in the body of FIG. 2A according to various embodiments of the present disclosure.

FIGS. 4-7 are cross-sectional views of examples of types of channels that may be formed in the body of FIG. 2A according to various embodiments of the present disclosure.

FIG. 8 is a drawing of an example of the body of FIG. 2A with an edge piece according to various embodiments of the present disclosure.

FIGS. 9-11 are drawings depicting results of simulations of the bodies of FIGS. 1A-1B and 2A-2B being exposed to fluid streams according to various embodiments of the present disclosure.

FIG. 12 is a flowchart illustrating an example of functionality implemented by a controller for the plasma actuators of FIG. 3 according to various embodiments of the present disclosure.

DETAILED DESCRIPTION

The present disclosure relates to implementing noise control of cavity flows using active and/or passive receptive

2

channels. In some embodiments, a channel is formed between a cavity wall and an exterior surface of a body. When a fluid stream flows across the opening of the cavity, the channel facilitates the pressure differential across points near the openings of the channel being lower than would otherwise exist if the channel was not present. In particular, fluid flows through the channel so that the pressure differential is reduced. As a result, the amplitude of pressure oscillations that may be generated from the fluid stream flowing over the cavity is less than what would otherwise be generated if the channel were not present.

With reference to FIGS. 1A-1B, shown is an example of a portion of a body **103** according to various embodiments of the present disclosure. In particular, FIG. 1A shows a perspective view of a portion of the body **103**, and FIG. 1B shows a cross-section of a portion of the body **103**.

FIGS. 1A-1B show the body **103** with a cavity **106** being exposed to a fluid stream **109**. The body **103** may represent various types of objects. For example, the body **103** may represent an aircraft, a pipe, or any other type of object that may be exposed to a fluid stream **109**. The fluid stream **109** may be, for example, air through which the body **103** is traveling, a liquid flowing across the body **103**, or any other type of fluid that is moving with respect to the body **103**. Thus, as a non-limiting example, FIGS. 1A-1B may represent a portion of an aircraft traveling through an air mass. Alternatively, FIGS. 1A-1B may represent an interior portion of a pipe with a liquid flowing therein. The fluid stream **109** is represented with arrows in FIGS. 1A-1B, and the direction of flow of the fluid stream **109** with respect to the body **103** is indicated by the direction of the arrows.

The body **103** includes a surface **113** that is exposed to the fluid stream **109**. Such a surface **113** may be, for example, the exterior skin of an aircraft, the interior wall of a pipe, or any other portion of the body **103** that is exposed to the fluid stream **109**. As shown, an opening is formed in the surface **113**, which defines a cavity **106** in the body **103**. Although the cavity **106** is shown as having a cubical shape, alternative embodiments may comprise cylindrical shapes or any other types of shapes. As non-limiting examples of embodiments of the cavity **106**, the cavity **106** may comprise a weapons bay or a landing gear bay in an aircraft. As an additional non-limiting example, the cavity **106** may represent an inlet or an outlet in a pipe.

One or more cavity walls **116-119** define the cavity **106**. Additionally, there are edges **123-126** between each respective cavity wall **116-119** and the surface **113**. The edge **123** is a leading edge **123** relative to the edge **126**, and the edge **126** is a trailing edge **126** relative to the edge **123**. In this regard, the leading edge **123** is upstream in the fluid stream **109** relative to the trailing edge **126**, and the trailing edge **126** is downstream in the fluid stream **109** relative to the leading edge **123**. The embodiment shown in FIGS. 1A-1B includes a base **129**, but the base **129** may not be present in alternative embodiments.

When the fluid stream **109** flows across the opening of the cavity **106**, a relatively high pressure level may exist at the point **133** along the cavity wall **119** near the trailing edge **126**, and a relatively low pressure level may exist at the point **136** along the surface **113** near the trailing edge **126**. Additionally, a relatively low pressure level may exist at the point **139** along the cavity wall **116** near the leading edge **123**, and a relatively high pressure level may exist at the point **143** along the surface **113** near the leading edge **123**. Furthermore, unstable shear layers, which can be described according to the Kelvin-Helmholtz instability theorem, may exist near the surface **113**. The pressure differentials at

points **133**, **136**, **139**, and **143** in conjunction with the unstable shear layers may result in pressure oscillations. These pressure oscillations can cause damage to the body **103** and/or objects that are within or near the cavity **106**.

With reference to FIGS. 2A-2B, shown is another example of a portion of a body **103**, referred to herein as the body **103a**, according to various embodiments of the present disclosure. In particular, FIGS. 2A-2B show cross-sections of a portion of the body **103a**.

In the embodiment shown in FIGS. 2A-2B, a first channel **203** is formed between the cavity wall **119** and the surface **113**. The first channel **203** includes one or more channel openings formed in the surface **113** and one or more channel openings formed in the cavity wall **119**. As shown, some embodiments of the body **103a** include a first edge member **206** that is separate from at least a portion of the surface **113** and at least a portion of the cavity wall **119**. In particular, the first edge member **206** is separated from the remaining portions of the surface **113** and the cavity wall **119** by the first channel **203**. One or more first support members **209** may provide structural support for the first edge member **206** and maintain the first edge member **206** in its position. For purposes of clarity, only a subset of the first support members **209** are labeled in FIGS. 2A-2B.

A second channel **213** is formed between the cavity wall **116** and the surface **113**. The second channel **213** includes one or more channel openings formed in the surface **113** and one or more channel openings formed in the cavity wall **116**. As shown, some embodiments of the body **103a** include a second edge member **216** that is separate from at least a portion of the surface **113** and at least a portion of the cavity wall **116**. In particular, the second edge member **216** is separated from the remaining portion of the surface **113** and the cavity wall **116** by the second channel **213**. One or more second support members **223** may provide structural support for the second edge member **216** and maintain the second edge member **216** in position shown.

As discussed above, when the fluid stream **109** flows across the opening of the cavity **106**, a relatively high pressure level may exist at the point **133** along the cavity wall **119** near the trailing edge **126**, and a relatively low pressure level may exist at the point **136** along the surface **113** near the trailing edge **126**. However, because the first channel **203** has one or more channel openings at the point **133** and one or more channel openings at the point **136**, the first channel **203** facilitates the pressure differential across the point **133** and the point **136** being lower than would otherwise exist if the first channel **203** were not present. In this regard, the first channel **203** facilitates fluid flowing between the point **133** and the point **136** so that the pressure differential is reduced. As a result, the amplitude of the pressure oscillations that may be generated from the fluid stream **109** flowing over the cavity **106** is less than what would otherwise be generated if the first channel **203** were not present.

Additionally, as discussed above, when the fluid stream **109** flows across the opening of the cavity **106**, a relatively high pressure may exist at the point **139** along the cavity wall **116** near the leading edge **123**, and a relatively low pressure may exist at the point **143** along the surface **113** near the leading edge **123**. However, because the second channel **213** has one or more channel openings at the point **139** and one or more channel openings at the point **143**, the second channel **213** causes the pressure differential between the point **139** and the point **143** to be lower than would otherwise exist if the second channel **213** were not present.

With reference to FIG. 3, shown is a portion of another example of a body **103**, referred to herein as the body **103b**, according to various embodiments of the present disclosure. In particular, FIG. 3 shows a cross-section of a portion of the body **103b** that includes the trailing edge **126**, the cavity wall **119**, and the first channel **203**. The second channel **213** (FIG. 2B), the leading edge **123** (FIG. 2B), and the cavity wall **116** (FIG. 2B) may include elements that are similar to the elements described with respect to FIG. 3 in various embodiments.

The body **103b** includes one or more plasma actuators **303** and **306**. Non-limiting examples of plasma actuators **303** and **306** are described in U.S. Pat. No. 8,235,072, titled "Method and Apparatus for Multibarrier Plasma High Performance Flow Control," issued on Aug. 7, 2012, U.S. Publication No. 2013/0038199, titled "System, Method, and Apparatus for Microscale Plasma Actuation," filed on Apr. 21, 2011, and WIPO Publication No. WO/2011/156408, titled "Plasma Inducted Fluid Mixing," filed on Jul. 6, 2011. Each of these documents is incorporated by reference herein in its entirety. In general, each plasma actuator **303** and **306** is configured to induce the flow of a fluid, such as air or any other type of fluid, due to the electrohydrodynamic (EHD) body force that results from the electric field lines that are generated between respective electrodes of the respective plasma actuators **303** and **306**.

The plasma actuators **303** and **306** may be positioned within the first channel **203**, as shown in FIG. 3. In alternative embodiments, the plasma actuators **303** and **306** may be positioned in any suitable location that is near the first channel **203**. For example, the plasma actuators **303** and **306** may be mounted on the first edge member **206** within the first channel **203**. As another non-limiting example, the plasma actuators **303** and **306** may be positioned on opposing sides of the first channel **203**. The plasma actuators **303** and **306** are configured to generate an EHD body force that adjusts the flow of a fluid through the first channel **203**. To this end, the plasma actuator **303** may be configured to generate an EHD body force in the direction indicated by the arrow **309**, and the plasma actuator **306** may be configured to generate an EHD body force in the direction indicated by the arrow **313**. In some embodiments, the plasma actuator **303** may be configured to generate an EHD body force in the direction indicated by the arrow **313**, and/or the plasma actuator **306** may be configured to generate an EHD body force in the direction indicated by the arrow **309**.

In some embodiments, the respective plasma actuators **303** and **306** may be dynamically activated in response to the pressure differential that exists across the first channel **203**. To this end, one or more sensors (not shown), such as pressure sensors and/or any other suitable type of sensor, may be located near the openings of the first channel **203**. The sensors in conjunction with any suitable hardware, software, or combination thereof are used to measure the pressure differential across the first channel **203** and to activate the respective plasma actuators **303** and **306** responsive to the measured pressure differential. For example, if sensors indicate that the pressure level at the point **136** near the surface **113** is greater than the pressure level at the point **133** near the cavity wall **119**, the plasma actuator **303** is activated to generate an EHD body force in the direction indicated by the arrow **309**. The EHD body force may facilitate fluidic flow in the direction indicated by the arrow **309**. As a result, the pressure differential across the first channel **203** may be reduced. Similarly, if sensors indicate that the pressure level at the point **136** near the surface **113** is lower than the pressure level at the point **133** near the

5

cavity wall **119**, the plasma actuator **306** may be activated to generate an EHD body force in the direction indicated by the arrow **313**. The EHD body force may facilitate fluidic flow in the direction indicated by the arrow **313**. As a result, the pressure differential across the first channel **203** may be reduced. Thus, the one or more plasma actuators **303** and **306** may be used to actively attenuate the amplitude of the pressure oscillations that may be generated by the fluid stream **109** (FIG. 2B) flowing across the cavity **106** (FIG. 2B).

With reference to FIGS. 4-8, shown are examples of a portion of a body **103**, referred to herein as the bodies **103c-103g**, according to various embodiments of the present disclosure. In particular, FIGS. 4-8 show cross-sections of portions of the bodies **103c-103g** having various types of first channels **203** and first edge members **206**. It is understood that the second channel **213** (FIG. 2B) and the second edge member **216** (FIG. 2B) may include elements that are similar to the elements discussed in FIGS. 4-8. It is also understood that the embodiments shown in FIGS. 4-8 may or may not include one or more plasma actuators **303** and **306** (FIG. 3).

FIG. 4 shows that one or more openings for the first channel **203** may be formed in the cavity wall **119** and located relatively close to the base **129** and relatively far from the surface **113**, as compared to the embodiment shown in FIGS. 2A-2B. FIG. 5 shows that one or more openings for the first channel **203** may be formed in surface **113** and located relatively far from the cavity wall **119**, as compared to the embodiment shown in FIGS. 2A-2B.

The first channel **203** may take the form of various types of shapes. For example, as shown in FIG. 6, the first channel **203** may form a throat that narrows in width as the distance from the cavity wall **119** and/or the surface **113** is increased. As another example, the first channel **203** shown in FIG. 7 widens as the distance from the cavity wall **119** and/or the surface **113** is increased. As shown in FIG. 8, the edge **123** may have a curved surface in some embodiments.

With reference to FIGS. 9-11, shown are drawings depicting the results of simulations of the body **103** (FIGS. 1A-1B) and the body **103a** (FIGS. 2A-2B) being exposed to fluid streams **109**. In particular, the line **903** represents the simulated results for the body **103**, which does not have the first channel **203**, and the line **906** represents the simulated results for the body **103a**, which has the first channel **203**. More specifically, FIG. 9 shows the resulting sound pressure levels near the base **129** (FIGS. 1B and 2B), FIG. 10 shows the resulting sound pressure levels near the trailing edge **126** (FIGS. 1B and 2B), and FIG. 11 shows the resulting sound pressure levels near the leading edge **123** (FIGS. 1B and 2B). As shown, embodiments that include the first channel **203** and/or the second channel **213** may result in sound pressure levels that are lower than the sound pressure levels that would otherwise exist if the first channel **203** and/or the second channel **213** were not present.

With reference to FIG. 12, shown is a flowchart that provides an example of the operation of a controller **1200** for the plasma actuators **303** and **306** according to various embodiments. It is understood that the flowchart of FIG. 12 provides merely an example of the many types of functional arrangements that may be employed to implement the function of the controller **1200** as described herein. The flowchart of FIG. 12 may be viewed as depicting an example of elements of a method implemented by the controller **1200**.

The controller **1200** in various embodiments may comprise one or more computing devices, such as a microcontroller, a programmable logic device (e.g., a field-program-

6

mable gate array (FPGA) or a complex programmable logic device (CPLD), an application specific integrated circuit (ASIC), a circuit comprising discrete logic elements, or any other suitable device, coupled to the plasma actuators **303** and **306**. In some embodiments, the controller **1200** includes at least one processor circuit, having a processor and memory coupled to a bus structure, such as an address/control bus. In addition, the memory may store computing instructions that, when executed by the processor circuit, causes the processor circuit to perform the functionality described herein. Accordingly, the controller **1200** in various embodiments may be embodied in the form of hardware, software, or a combination of hardware and software.

Beginning at element **1203**, the controller **1200** measures the pressure levels at points near the openings of the first channel **203**. To this end, one or more pressure sensors may be located near the openings of the first channel **203**, and the controller **1200** may read values that correspond to the pressure levels. At element **1206**, the controller **1200** calculates the pressure differential across the first channel **203**.

The controller **1200** then moves to element **1209** and determines whether the pressure differential across the first channel **203** is to be reduced. In one embodiment, the controller **1200** determines to reduce the pressure differential if the pressure differential is greater than a particular value. In another embodiment, the controller **1200** determines to reduce the pressure differential if the pressure differential is increasing from a previously measured pressure differential. If the controller **1200** determines to not reduce the pressure differential, the controller **1200** moves to element **1216**.

Otherwise, if the controller **1200** determines to reduce the pressure differential, the controller **1200** moves to element **1213** and activates one or more of the plasma actuators **303** and **306** in order to reduce the pressure differential. For example, if sensors indicate that the pressure level at the point **136** near the surface **113** is greater than the pressure level at the point **133** near the cavity wall **119**, the plasma actuator **303** is activated to generate an EHD body force in the direction indicated by the arrow **309**. Similarly, if sensors indicate that the pressure level at the point **136** near the surface **113** is lower than the pressure level at the point **133** near the cavity wall **119**, the plasma actuator **306** may be activated to generate an EHD body force in the direction indicated by the arrow **313**.

As shown at element **1216**, the controller **1200** then determines whether the process is complete. If the process is not complete, the controller **1200** returns to element **1203**, and the process repeats as shown. Otherwise, the process ends.

Although the flowchart of FIG. 12 shows a specific order of execution, the order of execution may differ from that which is depicted. For example, the order of execution of two or more elements in FIG. 12 may be switched relative to the order shown. Also, two or more elements shown in succession in FIG. 12 may be executed concurrently or with partial concurrence. Further, in some embodiments, one or more of the elements shown in FIG. 12 may be skipped or omitted.

Disjunctive language used herein, such as the phrase "at least one of X, Y, or Z," unless indicated otherwise, is used in general to present that an item, term, etc., may be either X, Y, or Z, or any combination thereof (e.g., X, Y, and/or Z). Thus, such disjunctive language does not imply that certain embodiments require at least one of X, at least one of Y, or at least one of Z to each be present.

7

The above-described embodiments of the present disclosure are merely possible examples of implementations set forth for a clear understanding of the principles of the disclosure. Many variations and modifications may be made to the above-described embodiments without departing substantially from the spirit and principles of the disclosure. All such modifications and variations are intended to be included herein within the scope of this disclosure.

The invention claimed is:

1. A system, comprising:
 - a surface configured to be exposed to a fluid stream, wherein a first channel opening is formed in the surface;
 - a cavity wall that forms at least a portion of a cavity, wherein a second channel opening is formed in the cavity wall, wherein a channel extends from the second channel opening in the cavity wall to the first channel opening in the surface; and
 - a plasma actuator disposed in the channel.
2. The system of claim 1, wherein the plasma actuator is among a plurality of plasma actuators disposed in the channel.
3. The system of claim 2, wherein at least one of the plurality of plasma actuators is configured to produce a first electrohydrodynamic (EHD) body force in a direction that is different from a second EHD body force that is produced by at least one other one of the plurality of plasma actuators.
4. The system of claim 1, wherein the plasma actuator is configured to be dynamically activated in response to a pressure differential between a first location proximate to the first channel opening and a second location proximate to the second channel opening.
5. The system of claim 1, wherein the plasma actuator is configured to be dynamically activated in response to a pressure level.
6. A method, comprising:
 - exposing a surface to a fluid stream, wherein an opening of a cavity is formed in the surface, wherein a channel extends from a first channel opening formed in the surface to a second channel opening formed in a cavity wall that forms at least a portion of the cavity; and
 - activating a plasma actuator disposed in the channel to adjust a pressure differential associated with the channel.
7. The method of claim 6, wherein the plasma actuator is activated dynamically in response to the pressure differential.
8. The method of claim 6, wherein the plasma actuator is among a plurality of plasma actuators disposed in the channel.

8

9. The method of claim 8, further comprising:
 - activating at least one of the plurality of plasma actuators to generate a first electrohydrodynamic (EHD) body force in a first direction; and
 - activating at least one of the plurality of plasma actuators to generate a second EHD body force in a second direction, wherein the second EHD body force is generated subsequent to the first EHD body force being generated.
10. The method of claim 6, further comprising measuring a plurality of pressure levels.
11. The method of claim 10, further comprising calculating the pressure differential using the plurality of pressure levels.
12. The method of claim 6, wherein exposing the surface to the fluid stream comprises flying an aircraft through air.
13. The method of claim 6, wherein exposing the surface to the fluid stream comprises causing a fluid to flow through a pipe.
14. An apparatus, comprising:
 - a surface configured to be exposed to a fluid stream, wherein a first channel opening is formed in the surface;
 - a cavity wall that forms at least a portion of a cavity, wherein a second channel opening is formed in the cavity wall;
 - wherein a channel extends from the second channel opening in the cavity wall to the first channel opening in the surface; and
 - a plasma actuator disposed in the channel.
15. The apparatus of claim 14, further comprising an additional plasma actuator disposed in the channel, wherein the plasma actuator is configured to produce a first electrohydrodynamic (EHD) body force in a first direction, and wherein the additional plasma actuator is configured to produce a second EHD body force in a second direction that is opposite of the first EHD body force.
16. The apparatus of claim 14, further comprising an edge member that is separate from at least a portion of the surface and at least a portion of the cavity wall.
17. The apparatus of claim 16, wherein the edge member comprises a triangular cross section.
18. The apparatus of claim 16, wherein the edge member comprises a curved exterior edge.
19. The apparatus of claim 14, wherein the surface comprises an aircraft skin.

* * * * *